



Agilent U1211A, U1212A, and U1213A Clamp Meter

Quick Start Guide



U1211A





U1212A



U1213A

The following items are included with your clamp meter:

- ✓ Standard test leads with 19 mm probes  and 4 mm probes 
- ✓ Soft carrying case
- ✓ Quick Start Guide
- ✓ Certificate of Calibration

If any item is missing or damaged, contact your nearest Agilent Sales Office.

For more detailed information, please refer to the *Agilent U1211A, U1212A, and U1213A Clamp Meter User's and Service Guide* on Agilent Website: www.agilent.com/find/handheld-tools



Knowing Your Clamp Meter

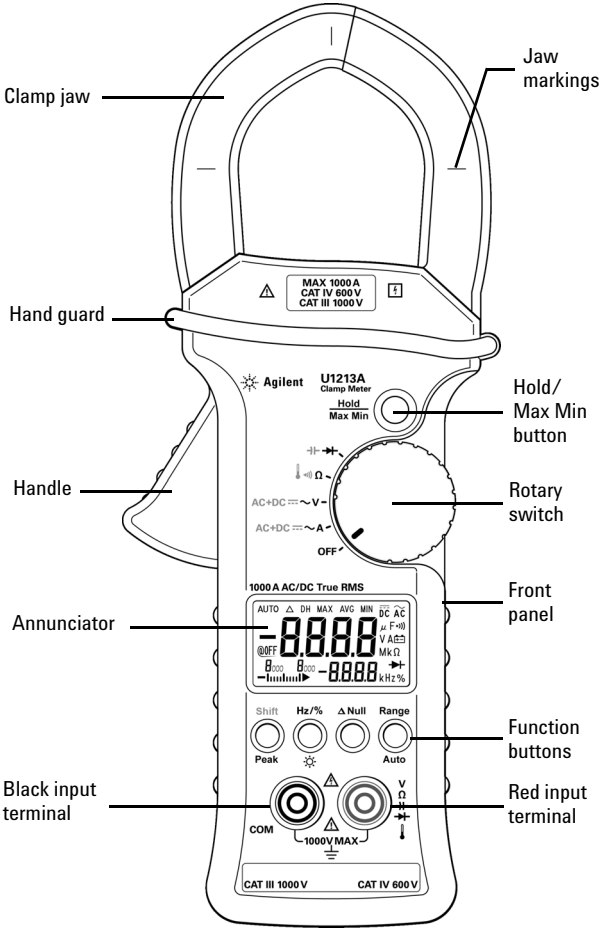

Functions and Features

Rotary switch

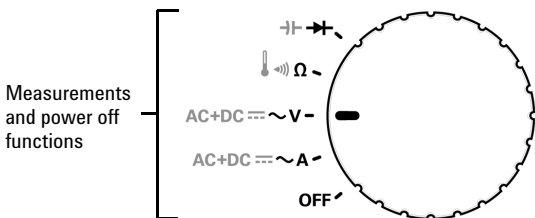

Function buttons

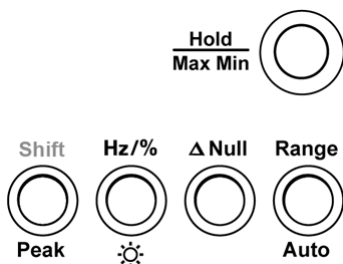

Actions	Steps
Freeze measured value	Press Hold/Max Min
<ul style="list-style-type: none"> Record maximum, minimum, and calculate true average Toggle between maximum, average, and minimum 	<ul style="list-style-type: none"> Press Hold/Max Min > 1 second Press Hold/Max Min again
Toggle measurement type	Press Shift/Peak
Toggle peak hold test	Press Shift/Peak > 1 second
Enable frequency or duty cycle ^[1] on secondary display	Press Hz/%
Turn on backlight	Press Hz/% > 1 second
Offset measured value	Press ΔNull
Change measuring range manually	Press Range/Auto
Turn on auto range	Press Range/Auto > 1 second

[1] Duty cycle % function is only available for U1213A.

Annunciator Display

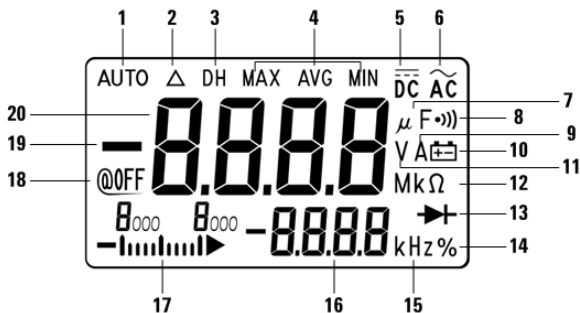

No.	Annunciator	Status
1	AUTO	Indicates auto ranging
2	Δ	Zeroing mode
3	DH	Data hold
4	MAX AVG MIN	Dynamic recording mode on present reading. MAX: maximum reading, MIN: minimum reading, AVG: average reading
5	$\overline{\text{DC}}$	Direct current or voltage
6	$\widehat{\text{AC}}$	Alternating current or voltage
7	μF	Capacitor measurement unit
8	$\bullet\text{))}$	Audible continuity indicator
9	A	Current measurement unit
10	A (battery symbol)	Low battery indicator when battery voltage drops below 6.0 V
11	V	Voltage measurement unit
12	M k Ω	Resistance measurement unit and range
13	$\rightarrow $	Diode measurement indicator
14	%	Duty cycle
15	kHz	Frequency measurement unit
16	$-\text{8888}$	Secondary display (for frequency measurement and temperature unit)
17	8000 8000 (bar graph)	Analog bar-graph with scale indicator
18	@OFF	Auto power off enabled
19	—	Negative polarity
20	8888	Primary display

Input Terminals

WARNING

Ensure the terminal connections are correct for a particular measurement before making any measurement. To avoid damage to the device, do not exceed the input limit.

Measurement functions	Input terminals		Input limits
AC current	Clamp jaw		1000 A _{rms}
DC current ^[1]			
AC voltage	V	COM	CAT III 1000 V _{rms} CAT IV 600 V _{rms}
DC voltage			
Resistance		COM	1000 V _{rms} for short circuit < 0.3 A
Capacitance			
Diode			
Temperature ^[2]			

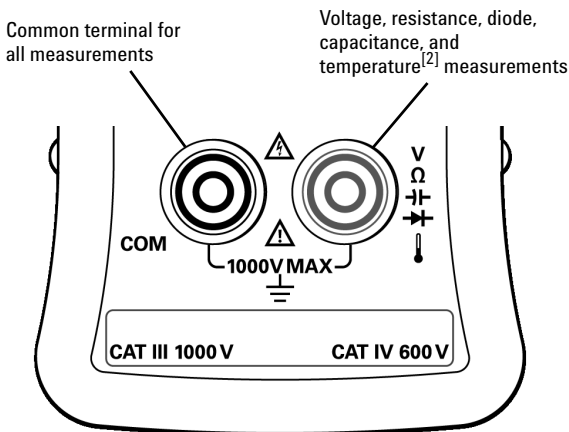

[1] DC current measurement is only available for U1212A and U1213A.

[2] Temperature function is only available for U1212A and U1213A.

Performing Current Measurement

WARNING Ensure the test leads are disconnected from the input terminals when measuring current with the clamp meter.

- 1 Set the rotary switch to \sim A.
- 2 Press **Shift** to switch between AC current, DC current (for U1212A and U1213A only), and AC+DC current (for U1213A only) measurements.
- 3 Press the handle to open the clamp jaw.
- 4 Clamp around a conductor and ensure that the conductor fits the markings on the jaw.
- 5 Read the display. Press **Hz** to view the frequency indication on the secondary display.

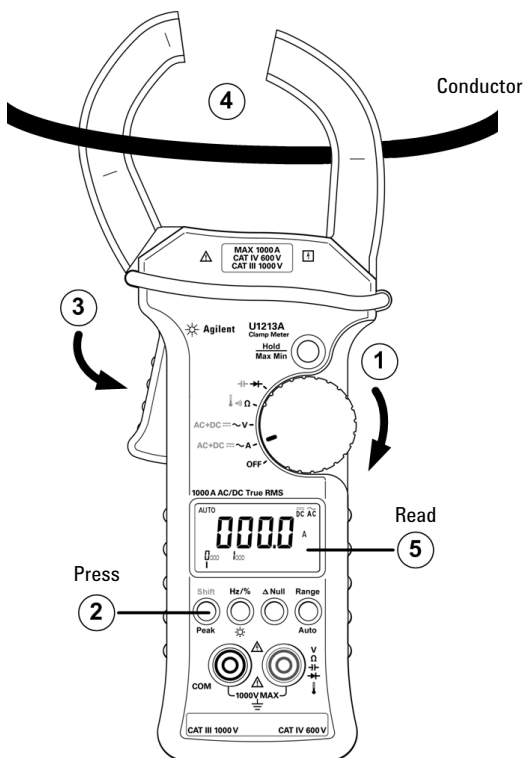

CAUTION

Ensure that the clamp meter measures only one conductor at a time. Measuring multiple conductors may cause inaccuracy in measurement reading due to vector sum of currents flowing in the conductors.

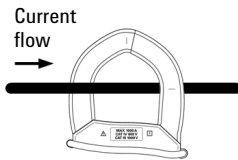

Correct

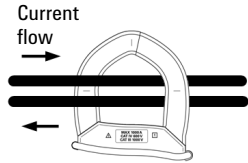

Incorrect

Performing Voltage Measurement

- 1 Set the rotary switch to $\sim V$.
- 2 Connect the red and black test leads to input terminals V (red) and COM (black) respectively.
- 3 Press **Shift** to switch between AC voltage, DC voltage, and AC+DC voltage (for U1213A only) measurements.
- 4 Probe the test points and read the display. Press **Hz** to view the frequency indication on the secondary display.

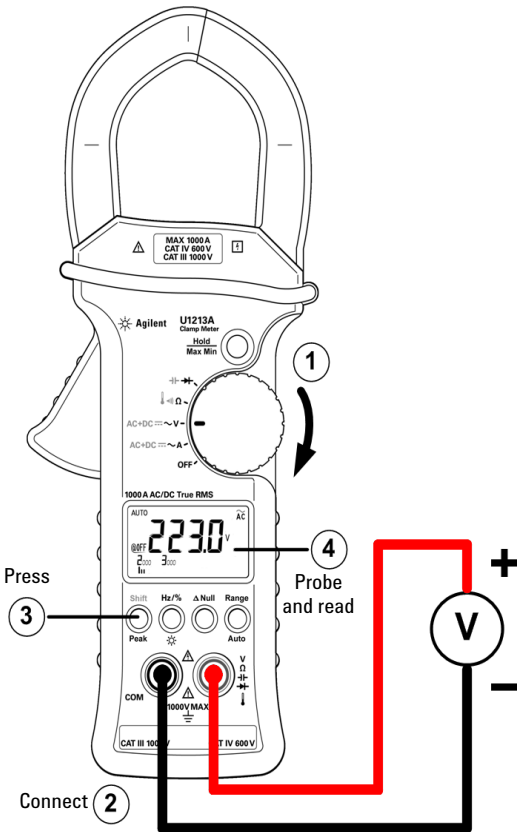

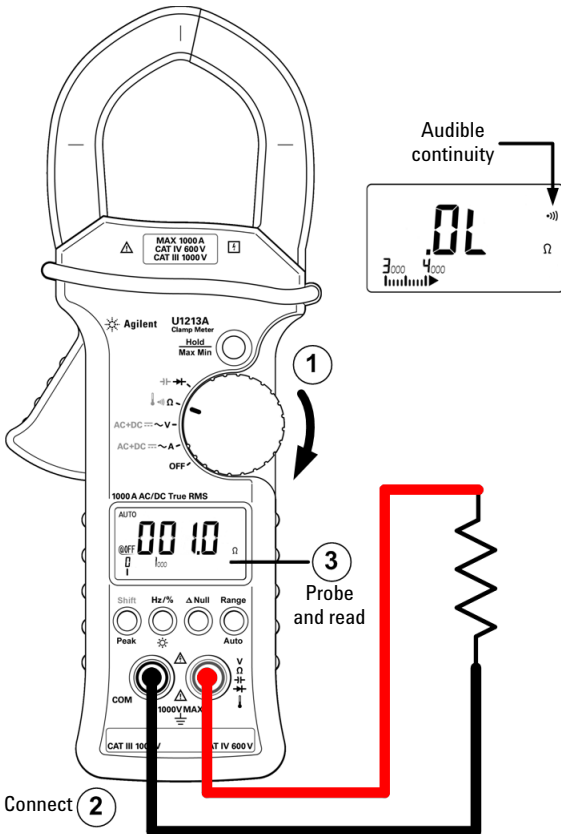

Performing Resistance Measurement and Continuity Test

- 1 Set the rotary switch to Ω
- 2 Connect the red and black test leads to input terminals Ω (red) and COM (black) respectively.
- 3 Probe the test points (by shunting the resistor) and read the display.
- 4 To perform continuity test, press **Shift** once. The buzzer will sound when the resistance is below 10.0 Ω



Performing Diode Measurement

- 1 Set the rotary switch to .
- 2 Connect the red and black test leads to input terminals  (red) and COM (black) respectively.
- 3 Probe the test points and read the display.

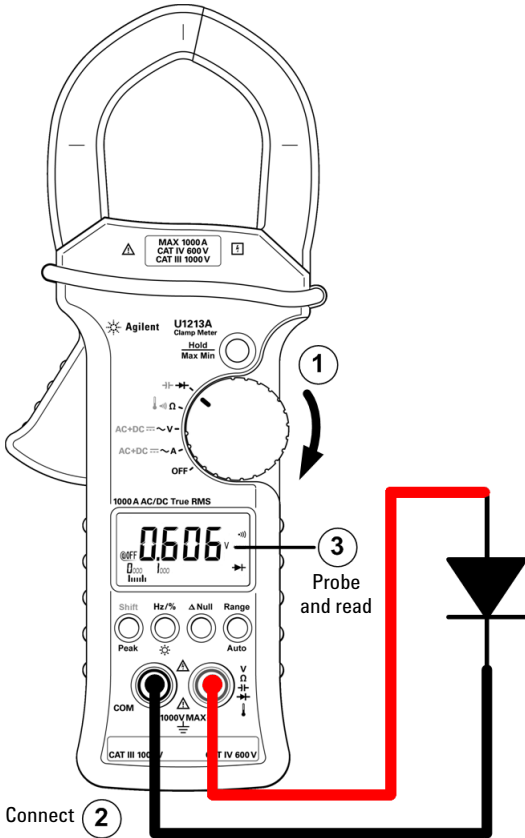

Performing Capacitance Measurement

- 1 Set the rotary switch to $\rightarrow \oplus$.
- 2 Press **Shift** to select capacitance measurement.
- 3 Connect the red and black test leads to input terminals $\rightarrow \oplus$ (red) and COM (black) respectively.
- 4 Probe the test points and read the display.

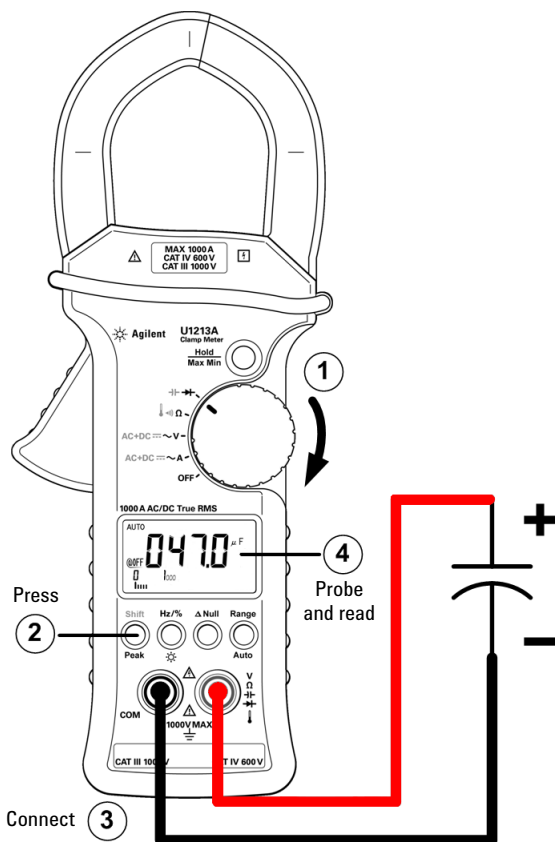

CAUTION

Discharge the capacitors before performing the measurements.

Performing Temperature Measurement

For U1212A and U1213A only

- 1 Set the rotary switch to Ω .
- 2 Press **Shift** twice to select temperature measurement.
- 3 Connect the thermocouple adapter (with the thermocouple probe connected to it) into input terminals Ω (red) and COM (black).
- 4 Touch the measurement surface (device under test) with the thermocouple probe and read the display.

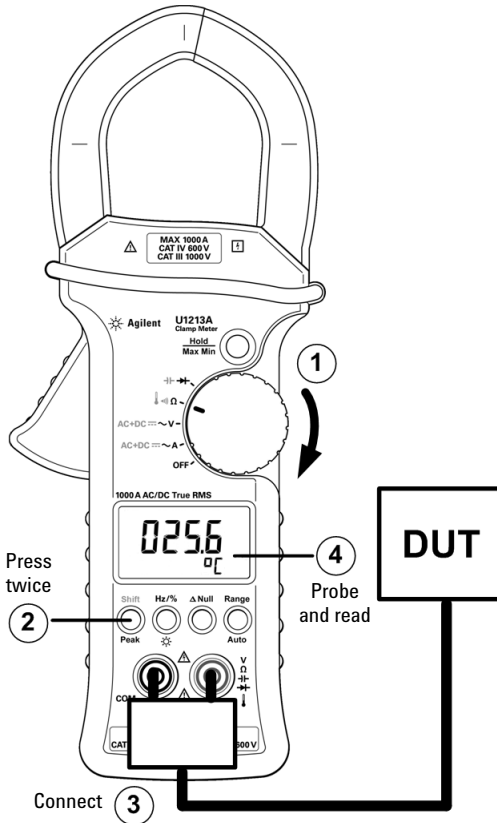



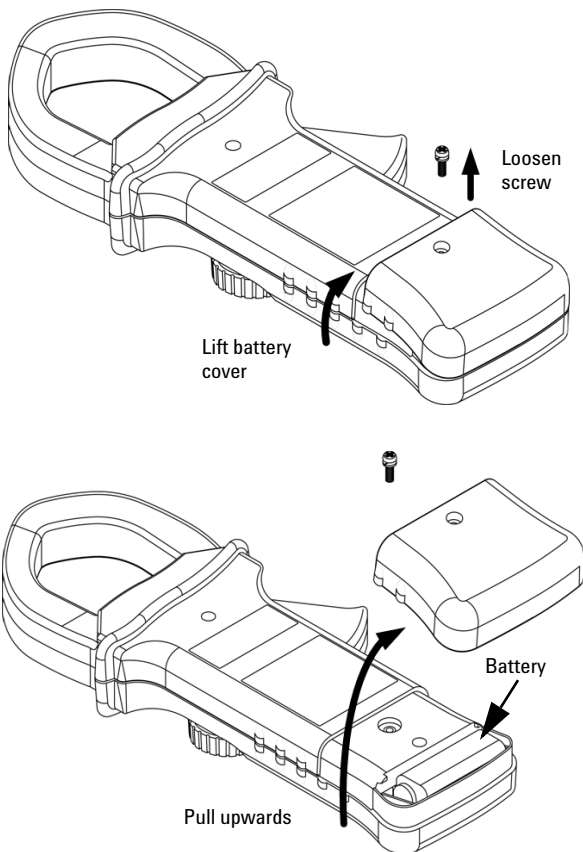

Replacing the Battery

- 1 Set the rotary switch to **OFF**.
- 2 Disconnect test leads from the input terminal.
- 3 Loosen the screw on the battery cover.
- 4 Lift the battery cover slightly, then pull the battery cover upwards.
- 5 Replace the specified battery (9 V).
- 6 Reverse the procedures above to close the cover.



Regulatory Markings

	The CE mark is a registered trademark of the European Community. This CE mark shows that the product complies with all the relevant European Legal Directives.
	The CSA mark is a registered trademark of the Canadian Standards Association.
ICES/ NMB-001	ICES/NMB-001 indicates that this ISM device complies with the Canadian ICES-001. Cet appareil ISM est conforme a la norme NMB-001 du Canada.
 N10149	The C-tick mark is a registered trademark of the Spectrum Management Agency of Australia. This signifies compliance with the Australia EMC Framework regulations under the terms of the Radio Communication Act of 1992.
	Product contains restricted substance(s) above the maximum value, with 40 yr Environmental Protection Use Period.
	This instrument complies with the WEEE Directive (2002/96/EC) marking requirement. This affixed product label indicates that you must not discard this electrical or electronic product in domestic household waste.

Safety Notices







CAUTION

A **CAUTION** notice denotes a hazard. It calls attention to an operating procedure, practice, or the like that, if not correctly performed or adhered to, could result in damage to the product or loss of important data. Do not proceed beyond a **CAUTION** notice until the indicated conditions are fully understood and met.

WARNING

A **WARNING** notice denotes a hazard. It calls attention to an operating procedure, practice, or the like that, if not correctly performed or adhered to, could result in personal injury or death. Do not proceed beyond a **WARNING** notice until the indicated conditions are fully understood and met.

Safety Symbols

	Direct current (DC)
	Alternating current (AC)
	Earth (ground) terminal
	Application around and removal from HAZARDOUS LIVE conductors is permitted
	Equipment protected throughout by double insulation or reinforced insulation
	Caution, risk of electric shock
	Caution, risk of danger (refer to the instrument manual for specific Warning or Caution information)
CAT III 1000 V	Category III 1000 V overvoltage protection
CAT IV 600 V	Category IV 600 V overvoltage protection

For further information on safety, refer to the U1211A, U1212A, and U1213A Clamp Meter User's and Service Guide.

Printed in Malaysia



U1211-90011

First edition, December 15, 2009
© Agilent Technologies, Inc., 2009



Agilent Technologies